DV700 Receptions

dvo_

DV700 Receptions

Cod.	Comp.	pag
DV702 Led	N°1A	004
DV702 Led	N°1B	016
DV702 Led	N°2	026
DV702 Led	N°3	034
DV701 Abako	N°1	046
DV701 Abako	N°2	056
DV701 Abako	N°3A	068
DV701 Abako	N°3B	080
DV703 Qubo	N°1A	090
DV703 Qubo	N°1B	102
DV703 Qubo	N°2A	110
DV703 Qubo	N°2B	120
DV703 Qubo	N°3A	128
DV703 Qubo	N°3B	140
DV703 Qubo	N°4	150

Receptions

Cod. DV702 Led Comp. N°1A



Design:
Antonio Morello

IT L'espressione esatta di chiarezza costruttiva – Una linea dedicata all'accoglienza, funzionale al dialogo e all'operatività. Funge da primo contatto, è l'elemento che relaziona l'utente con l'azienda attraverso una chiarezza lineare ben definita ed elegante. Con i suoi pannelli retroilluminati trasforma l'ambiente circostante in pura magia.

EN The precise expression of constructive clarity – This system is dedicated to welcoming areas. It is designed to promote conversation and work efficiency. Functions as first contact, introduces the visitor to the company through a well defined, elegant linear clarity; with its backlit panels it transforms the environment into pure magic.











Cod. DV702 Led
Comp. N°1B

Design:
Antonio Morello



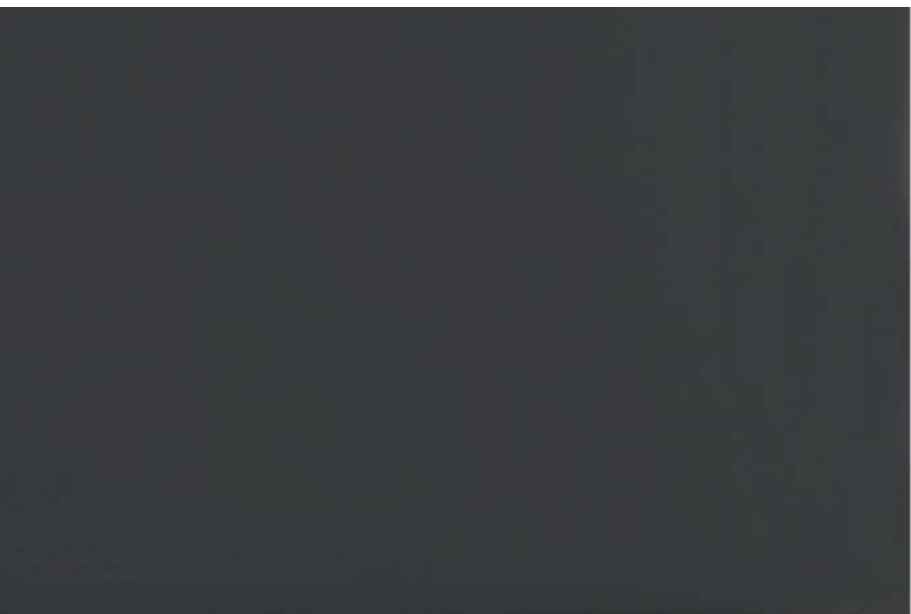







Cod. DV702 Led
Comp. N°2

Design:
Antonio Morello









Cod. DV702 Led
Comp. N°3

Design:
Antonio Morello











Moduli bancone e fianchi/Counter units and sides

Pannelli verticali sp. 1.8 cm in melaminico (*) o sp. 1.6 cm in laminato (**)
/Vertical panels 1.8 cm thick in melamine (*) or 1.6 cm thick in laminate (**)



Bianco lucido (**)
/Glossy white



Noce/Walnut (*)



Rovere chiaro (*)
/Light oak



Rovere Moro (*)
/Dark oak

Piani di lavoro sp. 1.8 cm, in melaminico/Worktops 1.8 cm thick, in melamine

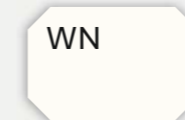

Bianco/White



Noce/Walnut



Rovere chiaro
/Light oak



Rovere Moro
/Dark oak

Zoccoli e profili in alluminio
/Base metal frames and profiles in aluminium

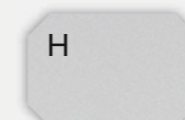

Alluminio
/Aluminium

Top sp. 1.5 cm, in vetro temprato retrolaccato
/Top 1.5 cm thick, rear-lacquered tempered glass

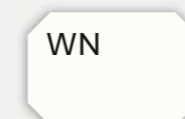

Retrolaccato bianco
/Rear lacquered white

Gambe terminali - intermedie in tubolare metallico
/Tubular metal end - intermediate legs

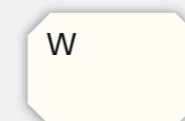

Bianco/White

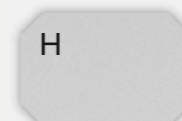

Alluminio
/Aluminium

Pannelli Led sp. 0.4 cm, in Metacrilato/Led panels 0.4 cm thick, in Methacrylate



Opalino bianco + telaio alluminio
/Opal white + aluminium frame

Note:

Su specifica richiesta è possibile ordinare abbinamenti tra pannelli e piani di lavoro diversi da quelli previsti a listino. Eventuali richieste di pannelli in metacrilato con illuminazione Led con colorazioni e finiture differenti, verranno valutate di volta in volta dall'ufficio commerciale./On specific request, front panels, side panels, and worktops can be supplied in non-standard finishes. Requirements for special finishes for the methacrylate Led panels with lighting, will be looked at on a case by case basis by the commercial department.

DV702 Led

Moduli bancone standard/Standard counter units



Dati tecnici/Technical data

Moduli bancone con Led/Counter units with Led

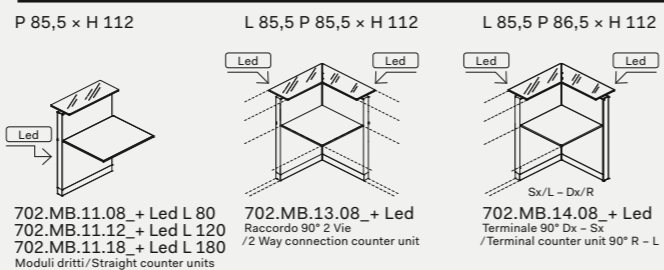

Moduli bancone con piano conversazione/Counter units with conversation top

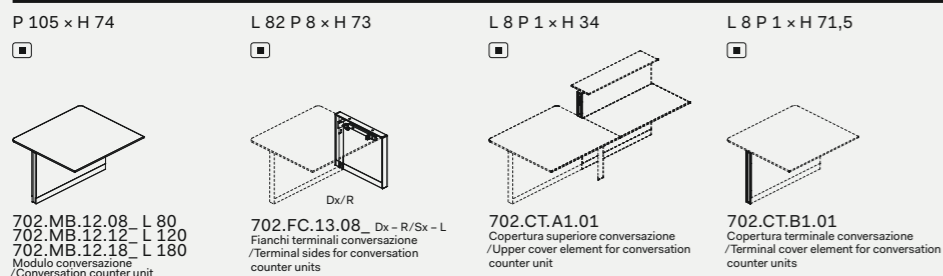

Componenti per bancone/Components for counter units

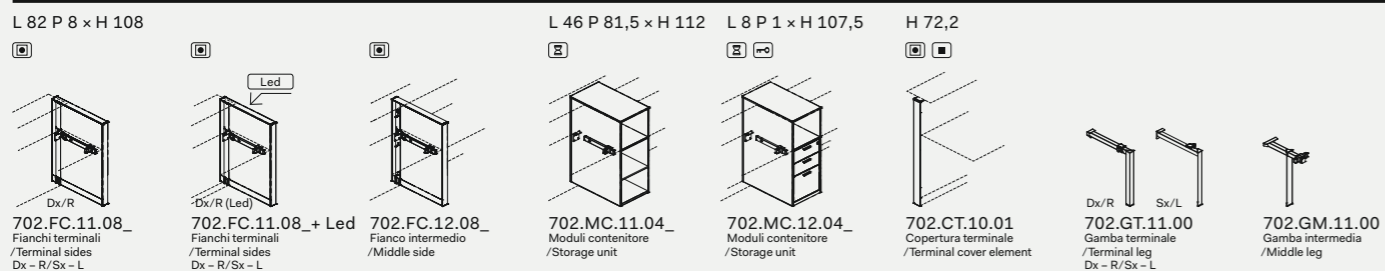

Allunghi laterali/Lateral extensions

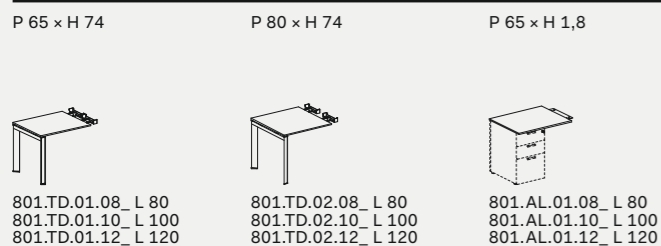

Cassettiere portanti/Carrying pedestals

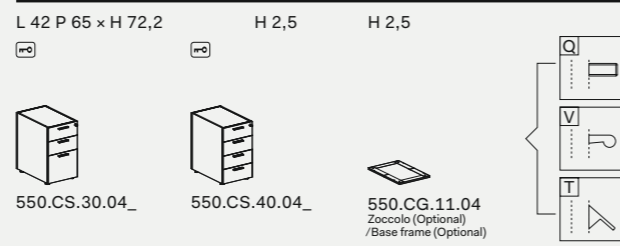

Cassettiere/Pedestals

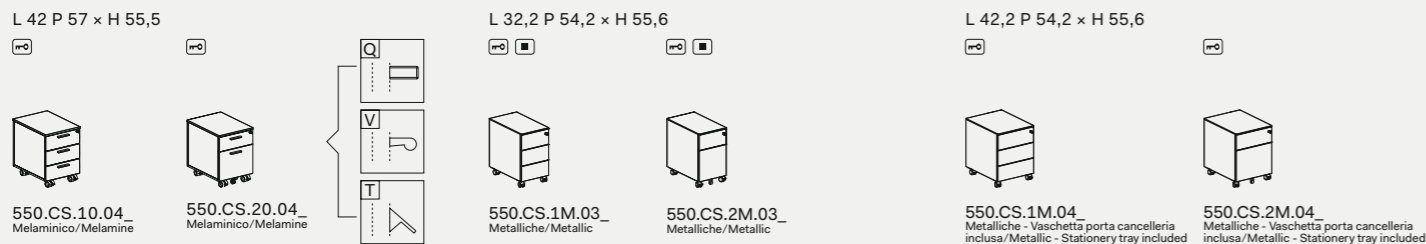

Bracci porta video/Arms for video support



DV702 Led

Canalizzazione - Elettrificazione/Wire-Management - Electrification

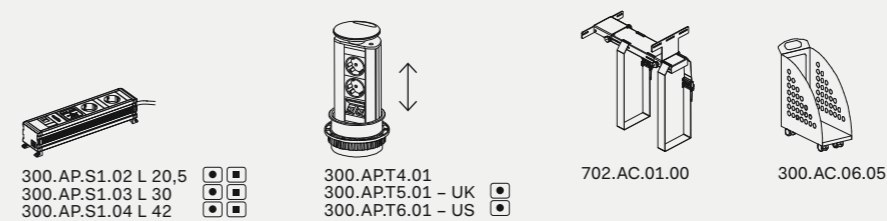
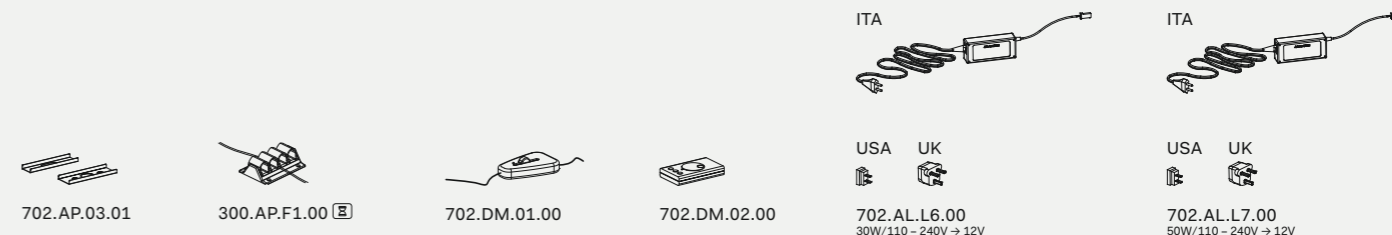
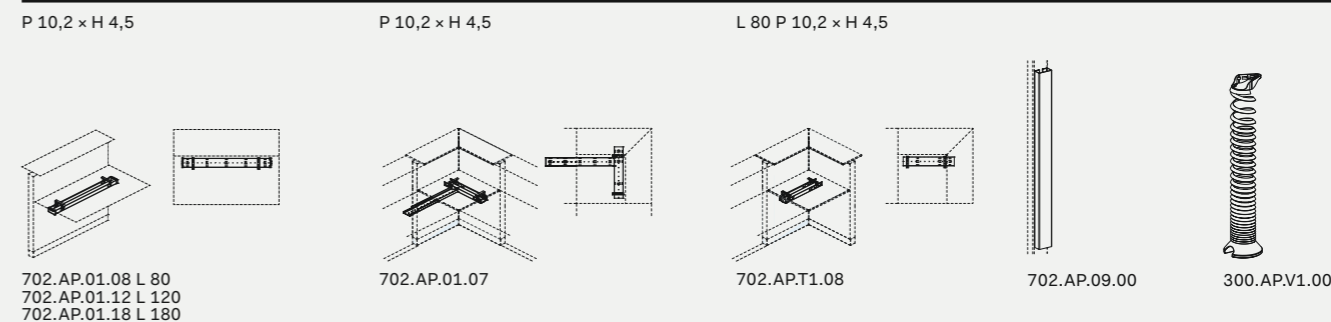

Note:

- La finitura impiallacciato delle cassette non è in pronta consegna. Per la disponibilità contattare l'ufficio commerciale/Pedestals veneered finish is not in prompt delivery. Please contact the commercial department to check availability;
- Per portacancelleria cassette, vedi capitolo DV300-Accessori/For stationary tray, see chapter DV300-Accessories;
- Progettare la composizione del bancone ed aggiungere: n°1 gamba intermedia, o fianco intermedio, o modulo contenitore per ogni collegamento tra due moduli; n°1 gamba terminale Dx o Sx, o fianco terminale Dx o Sx, o fianco terminale conversazione, o modulo contenitore per ogni lato finale del bancone; coperture terminali nella stessa quantità

- delle gambe terminali; copertura superiore per ogni collegamento tra modulo conversazione e modulo bancone /When designing the counter composition, add the following elements: n°1 middle leg or middle side or a storage unit for each connection between two counters; n°1 terminal leg (RH or LH) or terminal side (RH or LH), or terminal side for conversation counter unit or a storage unit on each side of the counter unit; add the terminal covers elements according to the same quantity of terminal legs; upper cover element for the connection between the conversation counter unit and the standard counter unit;
- Le dimensioni sono espresse in cm - consultare il listino prezzi per le caratteristiche tecniche, i codici degli articoli e delle finiture/Dimensions are stated in cm - for technical characteristics, article code numbers and finishing see price list;

- Prodotti non in pronta consegna. Per la disponibilità contattare l'ufficio commerciale/Items not in prompt delivery. Please contact the commercial department to check availability;
- Articoli prodotti solo su richiesta/Items produced only on demand;
- Fino ad esaurimento/Until exhaustion;
- Con serratura/With lock;
- Componenti non collegabili con modulo conversazione /Items that cannot be connected with the conversation counter units.

Cod. DV701 Abako Comp. N°1



Design:
Antonio Morello

▣ Arredo d'immagine e professionalità – Elementi lineari, linee arrotondate, dettagli ad alta valenza formale e inediti accostamenti di materiali; come un biglietto da visita dell'azienda, primo luogo di contatto con il pubblico e l'esterno. Eleganza e ospitalità, efficienza e rapidità sono caratteristiche di un sistema ideato per rispondere alle esigenze di rappresentanza in un moderno ambiente di lavoro.

▣ Furnishing with image and professionalism – Rounded lines, linear elements, formal details and innovative combinations of materials become the company's business card, since it is the first area of contact between visitors and outside world. Elegance and hospitality, efficiency and rapidity are the very characteristics of a system conceived to fulfil a company's representation requirements in a modern working environment.









Cod. DV701 Abako
Comp. N°2

Design:
Antonio Morello









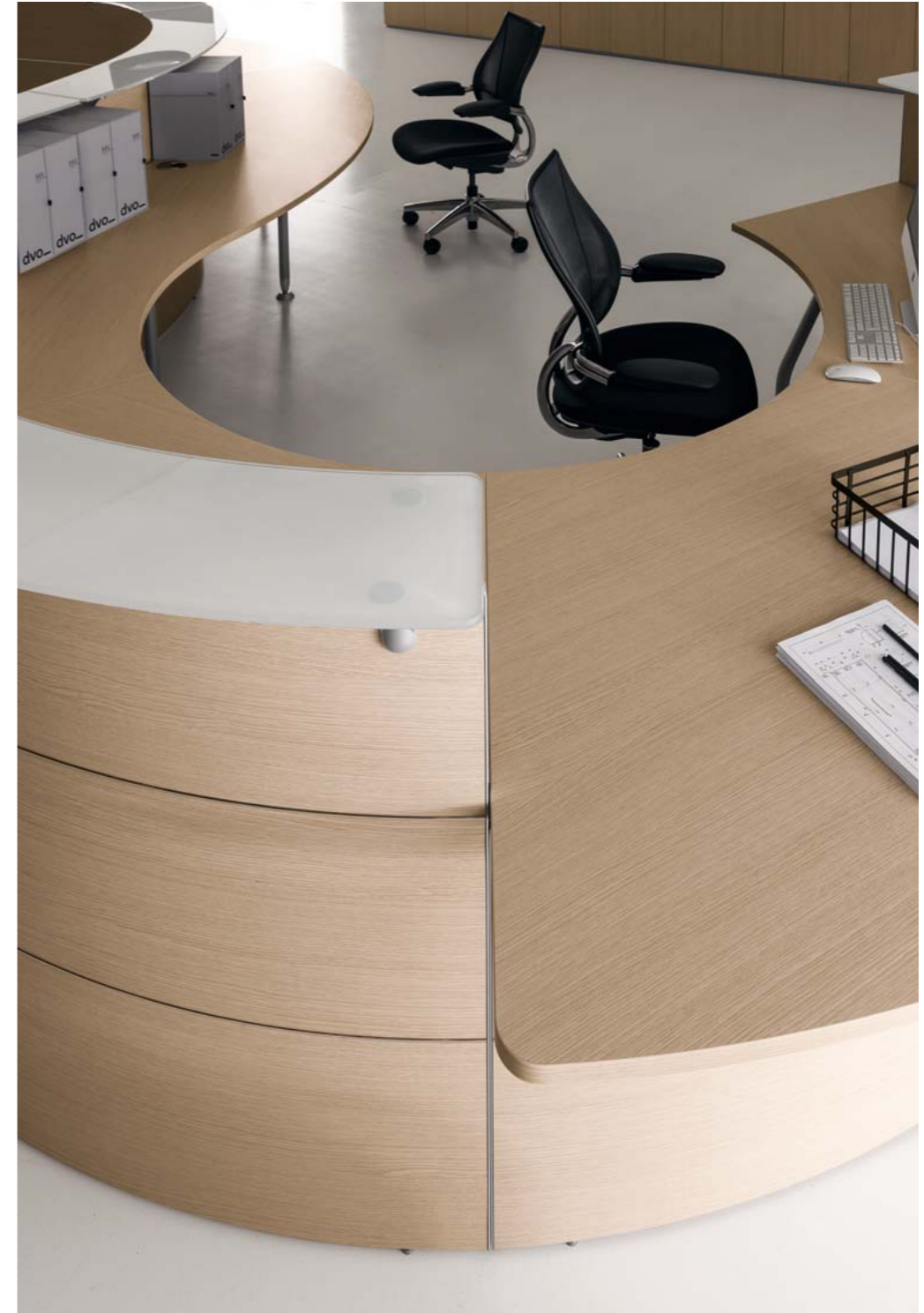



Cod. DV701 Abako
Comp. N°3A

Design:
Antonio Morello











Cod. DV701 Abako
Comp. N°3B

Design:
Antonio Morello





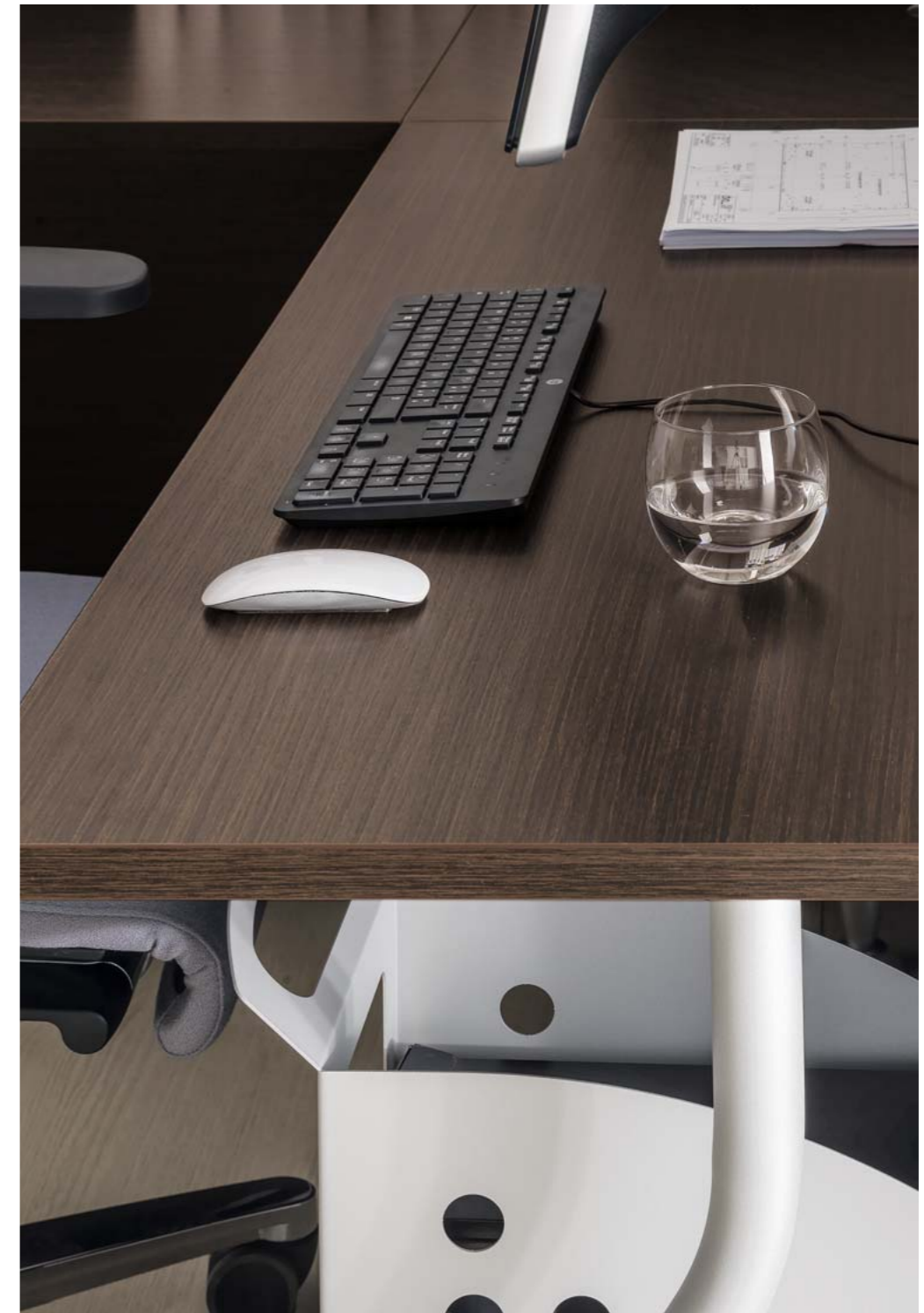



DV701 Abako

Finiture cromatiche/Colour finishes

Moduli bancone in melaminico o laminato/Reception units melamine or laminate finishes

Pannelli verticali sp. 1.8 cm, in melaminico (*) o laminato (**)/Vertical panels 1.8 cm thick, in melamine (*) or laminate (**)



Bianco/White (**), Grigio chiaro/Light grey (*), Rovere chiaro/Light oak (*), Rovere Moro/Dark oak (*)

Piani di lavoro sp. 2.5 cm, in melaminico/Worktops 2.5 cm thick, in melamine



Bianco/White, Grigio chiaro/Light grey, Rovere chiaro/Light oak, Rovere Moro/Dark oak

Top sp. 1.2 cm, in vetro temprato/Top 1.2 cm thick, tempered glass

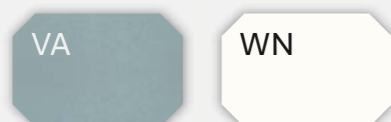

Acidato/Acated glass, Retrolaccato bianco/Rear-lacquered white

Gambe in metallo - Supporti top in zama Piedini in ABS/Metal legs - Die cast zama supports - ABS feet

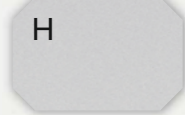

Alluminio/Aluminium

DV701 Abako

Esempi di composizioni/Exemple of composition

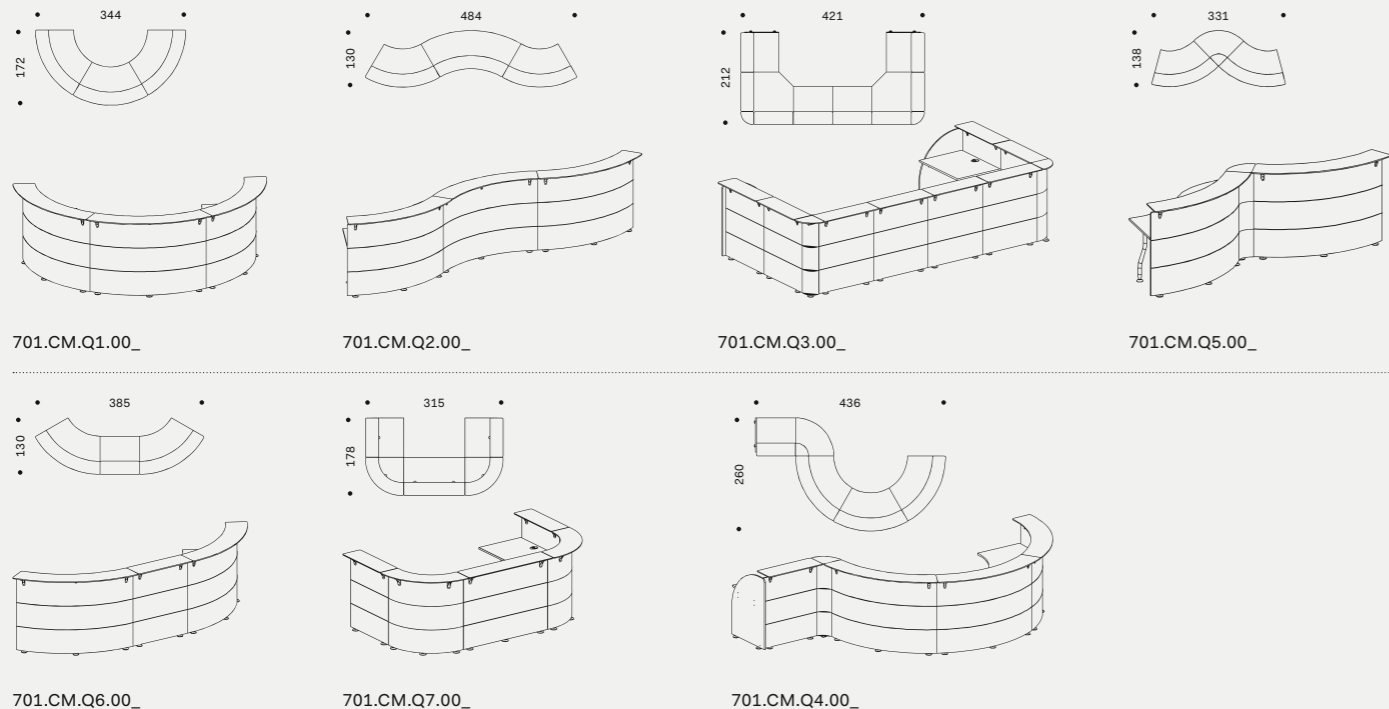

DV701 Abako

Dati tecnici/Technical data

Moduli bancone dritti - Moduli bancone curvi 60° - Moduli bancone raccordo 90°/Straight counter units - 60° curved counter units - 90° counter corner units

P 87,4 x H 110 L 170 P 99 x H 110 L 230 P 105,5 x H 110 L 87,4 P 87,4 x H 110 L 120 P 120 x H 110 L 87,4 P 87,4 x H 110

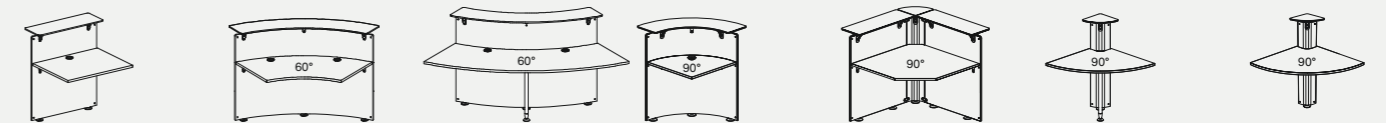

701.MB.11.09_ L 90 701.MB.11.14_ L 140 701.MC.14.17_ Interno/Internal 701.MC.15.23_ Esterno/External 701.MC.13.08_ Interno curvo/Curved internally 701.MC.16.12_ Interno dritto/Straight internally 701.MC.17.08_ Esterno dritto/Straight externally 701.MC.18.08_ Esterno dritto/Straight externally

Note: Il top in vetro extrachiaro retrolaccato non è in pronta consegna. Per la disponibilità contattare l'ufficio commerciale/Extra-light rear-lacquered glass top is not in prompt delivery. Please contact the commercial department to check availability

Moduli bancone con piano conversazione - Gambe - Fianchi/Counter units with conversation top - Legs - Sides

Allunghi laterali/Lateral extensions

P 105 x H 74 L 190 P 117 x H 74 Ø 4 x H 71,5 L 78 P 1,8 x H 102 P 44 x H 74 P 65 x H 2,5

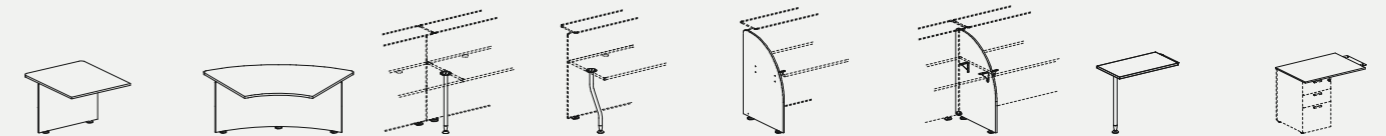

701.MB.12.09_ L 90 701.MB.12.19_ L 140 701.GM.11.00 701.GT.11.00 701.FC.11.07_ 701.FC.12.07_ 701.TD.01.08_ L 80 701.AL.01.10_ L 100 701.AL.01.12_ L 120

Cassettiere su ruote/Pedestals on castors

L 42 P 57 x H 55,5 L 32,2 P 54,2 x H 55,6 L 42,2 P 54,2 x H 55,6

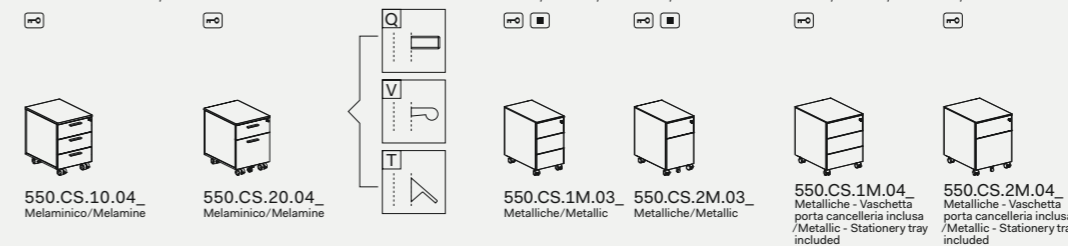

Note: 1 La finitura impiallacciato delle cassette non è in pronta consegna. Per la disponibilità contattare l'ufficio commerciale/Pedestals veneered finish is not in prompt delivery. Please contact the commercial department to check availability; 2 Per portacancelleria cassette, vedi capitolo DV300-Accessori/For stationary tray, see chapter DV300-Accessories.

Canalizzazione - Elettrificazione/Wire-Management - Electrification

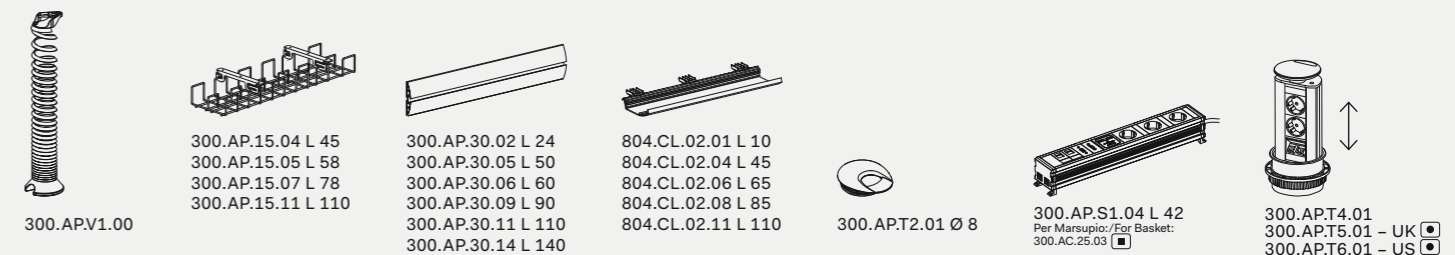

Accessori/Accessories

Bracci porta video/Arms for video support

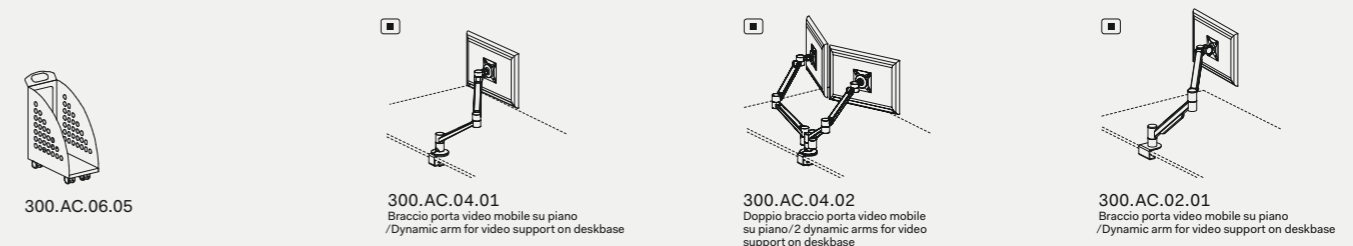

Note:

1 Per la scelta dei contenitori e degli accessori vari, consultare il relativo listino o catalogo/To choose storage units and accessories, please check correspondent price list or catalogue;

2 Le dimensioni sono espresse in cm - consultare il listino prezzi per le caratteristiche tecniche, i codici degli articoli e delle finiture/Dimensions are stated in cm - for technical characteristics, article code numbers and finishing see price list;

Prodotti non in pronta consegna. Per la disponibilità contattare l'ufficio commerciale/Items not in prompt delivery. Please contact the commercial department to check availability;

Articoli prodotti solo su richiesta/Items produced only on demand;

Con serratura/With lock.

Cod. DV703 Qubo
Comp. N°1A



Design:
Antonio Morello

Minimalismo e pulizia progettuale – La collezione si presenta come elemento dedicato all'accoglienza. Caratterizzato da elementi semplici che, accostati tra di loro, definiscono lo spazio di primo contatto. Conferisce alla reception un'immagine fresca e dinamica.

Minimalism and clean design – This collection showcases a modular reception desk solution. It's characterized by its simple in-line modules for defining the space of the first contact, giving the reception a fresh and dynamic image.











Cod. DV703 Qubo
Comp. N°1B

Design:
Antonio Morello









Cod. DV703 Qubo
Comp. N°2A

Design:
Antonio Morello











Cod. DV703 Qubo
Comp. N°2B

Design:
Antonio Morello









Cod. DV703 Qubo
Comp. N°3A

Design:
Antonio Morello













Cod. DV703 Qubo
Comp. N°3B

Design:
Antonio Morello











Cod. DV703 Qubo
Comp. N°4

Design:
Antonio Morello



Moduli bancone/Counter modules

Pannelli verticali sp. 2.5 cm, in melaminico con bordi in ABS sp. 0.15 cm
/Vertical panels 2.5 cm thick, in melamine with ABS edge-profile 0.15 cm thick

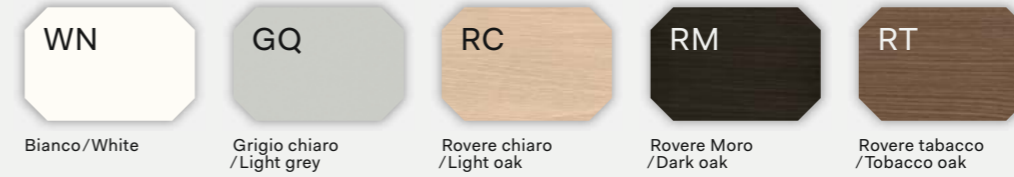

Piani di lavoro sp. 2.5 cm, in melaminico con bordi in ABS sp. 0.2 cm
/Worktops 2.5 cm thick, in melamine with ABS edge-profile 0.2 cm thick

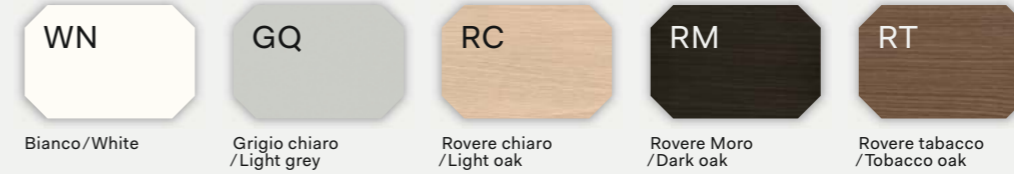

Abbinamento tops/Top combinations

Top sp. 1.8 cm, in melaminico (*) o laminato (**) con bordi in PMMA bicolore sp. 0.15 cm
/Top 1.8 cm thick, melamine (*) or laminate (**) with bicoloured PMMA edges-profiles 0.15 cm thick

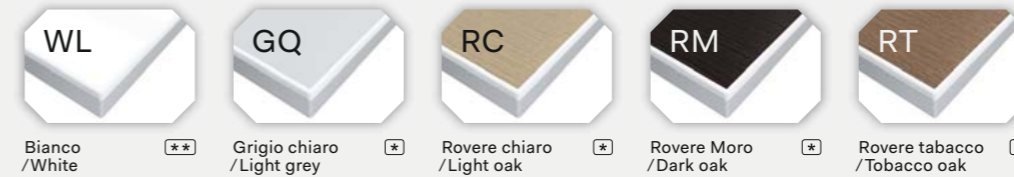

Componenti in metallo - zama/Metal - zamak components

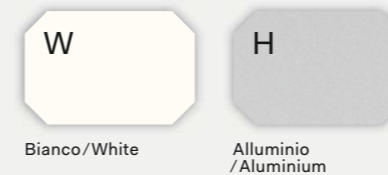

Zoccoli in alluminio/Aluminium plinth

Finitura alluminio anodizzato/Anodized aluminium finish



Box multiuso/Storage box

Box sp. 1 cm, in melaminico con bordi in ABS colore alluminio sp. 0.1 cm
/Box 1 cm thick, in melamine with ABS edges-profiles 0.1 cm thick

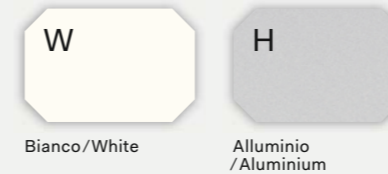

Composizione in gres/Gres composition

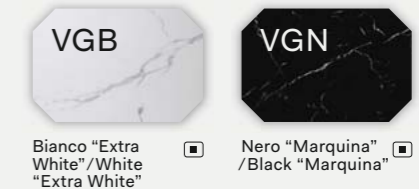

Top accettazione/Decorative top

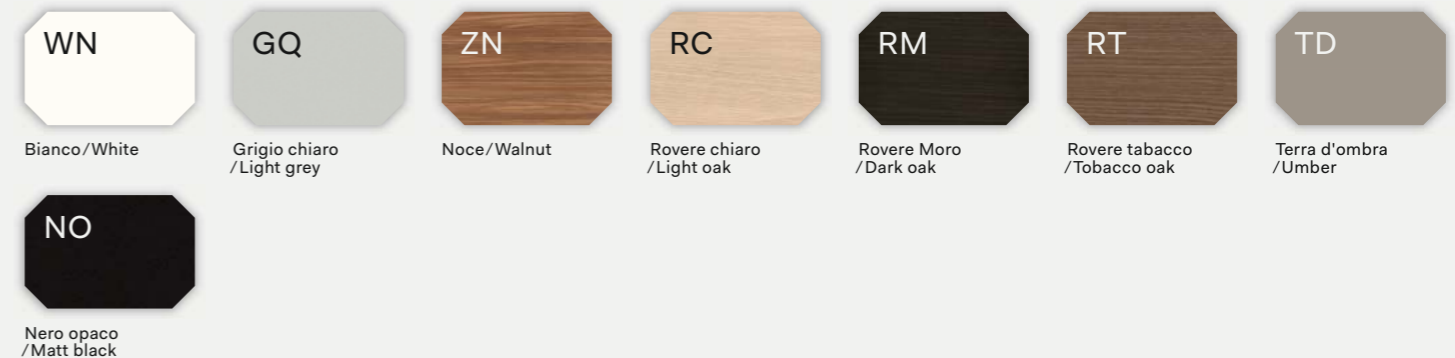

Note:

Prodotti non in pronta consegna. Per la disponibilità contattare l'ufficio commerciale/Items not in prompt delivery. Please contact the commercial department to check availability

DV703 Qubo

Moduli bancone standard/Standard counter units

P 84 x H 112,5	L 84 P 84 x H 112,5	L 84 P 84 x H 112,5	P 2,5 x H 112,5	L 84 P 84 x H 112,5	P 80 x H 2,5	L 80 P 80 x H 2,5
703.MB.01.08_L 80 703.MB.01.14_L 140 703.MB.01.16_L 160 703.MB.01.20_L 200 Moduli dritti/Straight counter units	703.MB.03.08_ Raccordo 90° a 2 vie /2 ways 90° connection unit	703.MB.04.08_ Terminale 90° Dx - Sx /Terminal counter unit 90° R - L	703.SQ.01.08_L 80 703.SQ.01.14_L 140 703.SQ.01.16_L 160 703.SQ.01.20_L 200 Schiene per moduli dritti /Back panels for straight units	703.SQ.02.08_ Schiene per moduli 90° /Back panels for 90° units	703.PQ.01.08_L 80 703.PQ.01.14_L 140 703.PQ.01.16_L 160 703.PQ.01.20_L 200 Piani scrivania per moduli dritti /Worktops for straight units	703.PQ.02.08_ Piani scrivania per moduli 90° /Worktops for 90° units

Componenti per moduli bancone/Components for counter modules

P 30 x H 1,8	L 84 P 84 x H 1,8	L 84 P 84 x H 1,8	L 84 P 2,5 x H 112,5	L 5 P 5 x H 71,5	P 2,5 x H 8	L 84 P 84 x H 8
703.TQ.01.08_L 80 703.TQ.01.14_L 140 703.TQ.01.16_L 160 703.TQ.01.20_L 200 Top per moduli dritti /Top for straight units	703.TQ.02.08_ Top per raccordo 90° a 2 vie /Top for 90° units	703.TQ.03.08_ Top per terminali 90° Dx - Sx /R - L top for 90° terminal units	703.FC.01.08_ Sx/L - Dx/R Fianchi terminali Dx - Sx /R - L terminal sides	703.GM.01.01 Colonna intermedia /Intermediate slim column	703.ZB.01.08 L 80 703.ZB.01.14 L 140 703.ZB.01.16 L 160 703.ZB.01.20 L 200 Zoccoli per moduli dritti/Metal plinth for straight units (Optional)	703.ZB.02.08 Zoccoli per moduli 90° /Metal plinth for 90° units (Optional)

* Non utilizzabile come terminale/It cannot be used as a terminal side

Ⓜ Componenti non collegabili con modulo conversazione/Items that cannot be connected with the conversation counter units

Moduli bancone con piano conversazione/Counter units with conversation top

L 140 P 115 x H 74	L 140 P 2,5 x H 71,5	L 140 P 115 x H 2,5	L 84 P 2,5 x H 74	L 28 P 2,5 x H 39
703.MB.02.14_ Modulo conversazione /Conversation counter unit	703.SQ.03.14_ Schiene per modulo conversazione /Back panels for conversation unit	703.PQ.03.14_ Piano per modulo conversazione /Worktop for conversation unit	703.FC.03.08_ Sx/L - Dx/R Fianchi terminali per modulo conversazione /Terminal sides for conversation unit	703.CT.A1.02_ Sx/L - Dx/R Fianchetti superiori per modulo conversazione /Small sides for conversation unit

Ⓜ Gli zoccoli sono optional e non sono previsti per i fianchi terminali/The aluminium plinths are optional and are not intended for end panels

Top accettazione/Decorative top

L 140 - 160 P 32,3 x H 74
703.TA.01.14_L 140 703.TA.01.16_L 160

Accessori/Accessories

L 35 P 24 x H 35
300.AC.14.03 Box Multiuso/Storage Box

Cassettiere/Pedestals

L 42 P 57 x H 55,5	L 32,2 P 54,2 x H 55,6	L 42,2 P 54,2 x H 55,6	L 42 P 65 x H 72,2	H 1,8
550.CS.10.04_ Melaminico/Melamine	550.CS.20.04_ Melaminico/Melamine	550.CS.1M.03_ Metalliche/Metallic	550.CS.2M.03_ Metalliche/Metallic	550.CS.1M.04_ Metalliche - Vaschetta porta cancelleria inclusa /Metallic - Stationery tray included

DV703 Qubo

Composizione in gres/Gres composition

L 247 P 84 x H 112,5
703.CM.P1

Bracci porta video/Arms for video support

300.AC.04.01 Braccio porta video mobile su piano /Dynamic arm for video support on deskbase	300.AC.04.02 Doppio braccio porta video mobile su piano/2 dynamic arms for video support on deskbase	300.AC.02.01 Braccio porta video mobile su piano /Dynamic arm for video support on deskbase

Canalizzazione - Elettrificazione/Wire-Management - Electrification

300.AP.V1.00	300.AP.15.05 L 58 For 703.MB.01.08_/703.MB.04.08_ 300.AP.15.08 L 88 For 703.MB.01.20_ 300.AP.15.11 L 110 For 703.MB.01.14_/703.MB.02.14_ 300.AP.15.14 L 140 For 703.MB.01.16_	703.AP.01.04 L 45 For 703.MB.03.08_	300.APS.1.02 L 20,5 300.APS.1.03 L 30 300.APS.1.04 L 42	300.AP.T4.01 300.AP.T5.01 - UK 300.AP.T6.01 - US

300.AP.T2.01 Ø 8	300.AP.T7.01 Ø 6 300.AP.T8.01 Ø 8	703.LQ.01.00 L 55	703.KQ.01.00 15W/100 - 240V → 24V

Note:

- La finitura impiallacciato delle cassette non è in pronta consegna. Per la disponibilità contattare l'ufficio commerciale/Pedestals veneered finish is not in prompt delivery. Please contact the commercial department to check availability;
- Per portacancelleria cassette, vedi capitolo DV300-Accessori/For stationary tray, see chapter DV300-Accessories;
- Per la scelta dei contenitori e degli accessori vari, consultare il relativo listino o catalogo/To choose storage units and accessories, please check correspondent price list or catalogue;

- Progettare la composizione del bancone ed aggiungere: n°1 gamba intermedia, o fianco intermedio, o modulo contenitore per ogni collegamento tra due moduli; n°1 gamba terminale dx o sx, o fianco terminale dx o sx, o fianco terminale conversazione, o modulo contenitore per ogni lato finale del bancone; coperture terminali nella stessa quantità delle gambe terminali; copertura superiore per ogni collegamento tra modulo conversazione e modulo bancone /When designing the counter composition, add the following elements: n°1 middle leg or middle side or a storage unit for each connection between two counters; n°1 terminal leg (RH or LH) or terminal side (RH or LH), or terminal side for conversation counter unit or a storage unit on each side of the counter unit; add the terminal covers elements according to the same quantity of terminal legs; upper cover element for the connection between the conversation counter unit and the standard counter unit;

- Le dimensioni sono espresse in cm - consultare il listino prezzi per le caratteristiche tecniche, i codici degli articoli e delle finiture/Dimensions are stated in cm - for technical characteristics, article code numbers and finishing see price list;
- Prodotti non in pronta consegna. Per la disponibilità contattare l'ufficio commerciale/Items not in prompt delivery. Please contact the commercial department to check availability;
- Articoli prodotti solo su richiesta/Items produced only on demand;
- Con serratura/With lock.

DVO S.P.A.
Via XX Settembre, 272
Casella Postale n. 65
U.P. Roveredo in Piano
33080 Roveredo in Piano (PN)
Italy

Tel. +39 0434 386 111
Fax +39 0434 386 112
www.dvo.it
info@dvo.it

Art Director
• Enzo Berti

Graphic Project
• Studio Malisan

Photo
• Tobia Berti

Stylist
• Mara Zambon

Print
• Grafiche Antiga

Printed in Italy
Issue 02
May 19

Thanks to:

- Adriani e Rossi
- Artemide
- Dauphin
- Design Object
- Humanscale
- Interstuhl
- Italiana Divani
- Lumina
- Marte
- Milani
- Moroso
- Rotaliana
- Sil.lux
- Tisca
- Tolight
- Waldmann
- Zava



DVO S.P.A. – Azienda certificata/Certified Company



Richiedi i prodotti certificati FSC®/Request for FSC® certified product

Il marchio della gestione forestale responsabile

Foto e testi copyright DVO non riproducibili. La venditrice si riserva la facoltà di apportare al prodotto eventuali modifiche tecniche, dimensionali ed estetiche in qualsiasi momento senza preavviso.

/Pictures and text are DVO copyright, duplicate forbidden. The selling Company reserves the right to introduce changes to products regarding sizes and aesthetic or technical aspects at any time without notice.



C-DV700-RECEPTIONS201902

dvo_

Via XX Settembre, 272
Casella Postale n. 65
U.P. Roveredo in Piano
33080 Roveredo in Piano (PN)
Italy

Tel. +39 0434 386 111
Fax +39 0434 386 112
www.dvo.it
info@dvo.it